

## INSTALLATION INSTRUCTIONS

**READ INSTRUCTIONS COMPLETELY BEFORE ATTEMPTING THE INSTALLATION**

These instructions are provided as a general guide in the installation of this product. Applicable product's approval documents should be used as reference along with these instructions. It is recommended that experienced installers should attempt the installation. Technical support is available by contacting CGI at 1-866-846-5335.

### **OPENING REQUIREMENTS AND PREPARATION**

The rough framed opening to receive the door shall be sufficiently larger in width and height than the unit to be installed. This will allow shims and square the frame into the opening for a correct installation and door operation.

The appropriate dimensions of the unit to be installed in relation to the opening will depend on whether it was used a 1" x 4" or 2" x 4" construction. The 1" x 4" or 2" x 4" refers to the nominal dimensions of pressure-treated lumber used to build the framing around the rough opening (top and sides). As the thickness of lumber used may vary, the framed opening dimensions may increase or decrease and so also the overall dimensions of the door. **(Figures 1, 2)**

The bottom of the rough opening or sub sill (where the door frame sill will rest) is usually of solid concrete and must be dry and clean, free of dirt and debris. A 3/4" recess at sub sill (interior floor 3/4" higher than the exterior floor) is recommended as an extra guard against water infiltration into the building. **(Figure 2)**

The framed opening should be level, square and plumb. Make all the adjustments or corrections to opening needed before proceeding with the installation. Do not attempt to install the door if the opening does not meet these requirements.

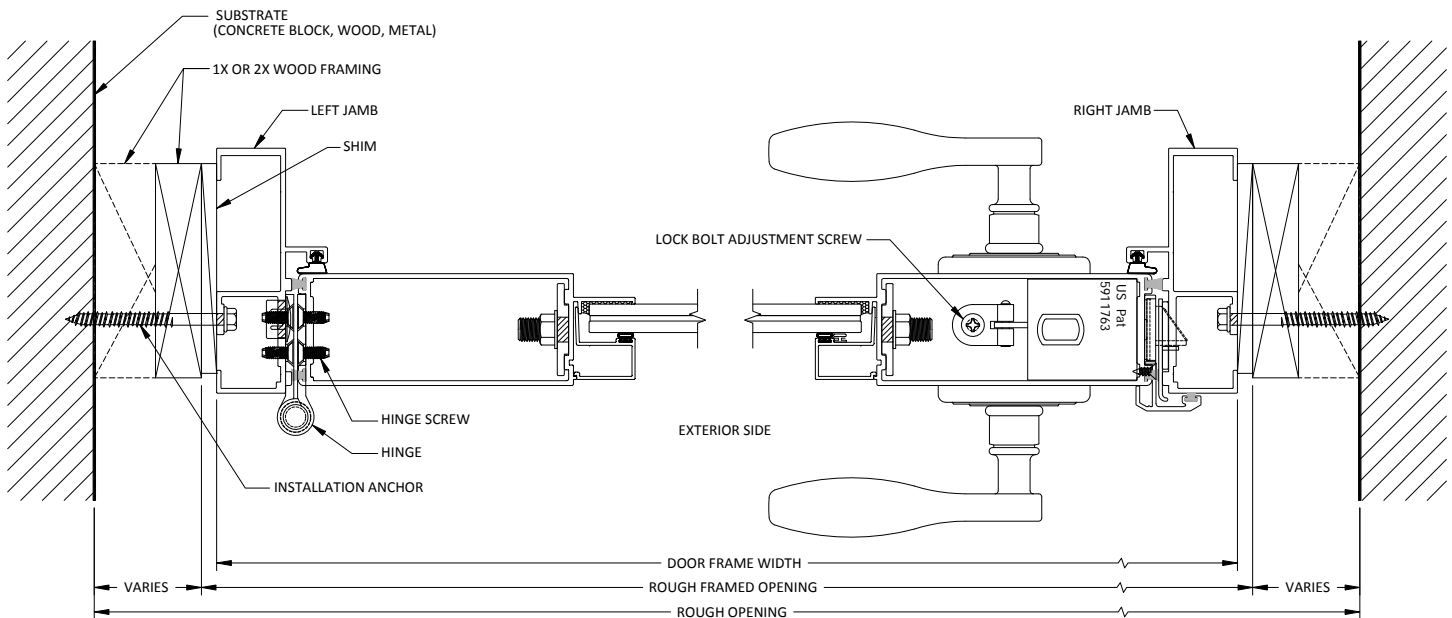

**(Figure 1)**

### **SINGLE DOOR INSTALLATION**

It is recommended that the installation work should be done from the exterior side of the building.

Single doors typically are not pre-hung. Frame and panel are factory assembled and packed separately when shipped. Remove frame and panel from the shipping packaging. Put the panel separate in a secure place and proceed installing the frame as follows:

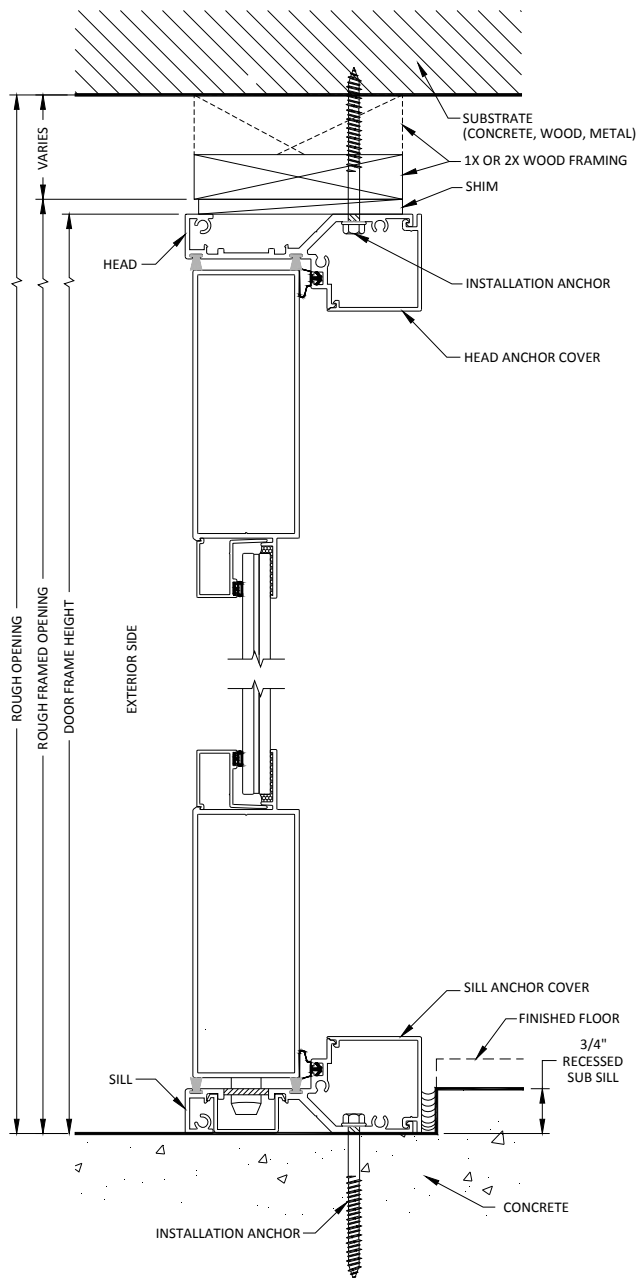

(Figure 2)

1. Measure width and height dimensions of opening and frame and make sure they are correct. The rough framed opening shall be 1/2" wider than overall unit width and 1/4" higher than overall unit height.
2. Weatherproof the sub sill. Apply a continuous 3/8" bead of professional grade caulk compound, about 1/4" from the front and 1" from the rear of sub sill with a wave pattern in between. Apply a 3/8" bead of caulk to the underside of frame sill as well, where it will contact the concrete and at both frame corner joints, where the jamb meets the threshold.
3. Tilt and set the frame into the opening by seating the threshold first. Then, swing the rest of frame up into the opening. When doing this, do not scrape off the caulk poured to ensure a continuous barrier of sealant.
4. Insert shims at the top first between the frame head and the opening to hold the frame in place. Insert shims on the rest of perimeter (at both sides) between the frame jamb and the opening. Shims should be inserted at each factory predrilled hole so the installation anchors, installed later, will each fasten evenly, avoiding the bowing of frame. Wood shims or plastic slotted 'horseshoe' shims can be used.
5. Make sure the frame sill is straight, flat and level. Measure the frame diagonally and check that both dimensions are the same. Also measure interior dimensions of frame at the top, mid span and bottom (vertically and horizontally) and check they are equal. Use a level to ensure both frame jambs are straight and plumb. Make any adjustments to frame if needed by relocating, adding or removing shims as required.
6. Once the frame is square, plumb and level in the opening, use a 1/4" diameter drill bit to perforate 2-1/2" deep into substrate at each pre-fabricated frame installation hole.
7. Drive the installation screws (not included, refer to construction plans or product's approval document for proper fastener and embedment). Start at the sill and head (Figure 3), then at jambs (Figure 4). Do not tighten the fasteners; leave them slightly loose since further adjustment might be needed.
8. Attach the door panel to frame. The hinges have been factory installed to door panel. Swing out about 90 degrees the free side of each hinge attached to panel and approach panel to frame so each hole of hinge is centered with corresponding pre drilled hole of jamb. Fasten the hinge screws provided #12-24 x 1/2" PHP. FH. MS. at each predrilled hole. Do not over tighten the screws since they can get damaged easily. Use a hand screwdriver or a cordless drill with Philips drive bit #3 and variable clutch settings, capable of regulating the tightening torque. (Select setting 5 - 6 on the regulating collar)
9. Swing the door panel slowly and approach it near to the closed position.

Check the gap between panel and frame is uniform, about 3/16", around the perimeter. If frame has been properly shimmed and installed square, level and plumb, the panel should not rub the frame nor show sagging. Make any adjustments to frame until is square, level, plumb and well secured into opening.

10. Once the frame is set, from the interior, tighten the installation fasteners at head and sill (**Figure 3**). Open the panel 90 degrees to have access to jamb's installation screw access hole and tighten the rest of jamb fasteners (**Figure 4**). Swing the panel to the closed position and check it closes properly. Then, insert the plastic plugs (provided in the hardware bag) to cover each screw access hole at both jambs.
11. Install the screw cover (provided with frame package) at head and sill by snapping the cover onto jamb profile (**Figure 5**). When doing this, use a plastic head mallet and a piece of wood to hit the cover and avoid damage to profile.
 

**Note: Do not install the screw covers until the installation of the door have been inspected and granted its approval by the Authority Having Jurisdiction or city's local Building Department. The city inspector may require physical verification to certify that installed anchors comply with corresponding product's Notice of Acceptance (NOA)**
12. Install the door lock set (strike and deadbolt) according to manufacturer's instructions included in the hardware box and check for a smooth and correct operation of the three point lock system. The length (penetration) of top and bottom bolt locks is factory adjusted. If further adjustment is needed, open the door panel slightly to have access to the exposed adjusting screw (**Figure 1**) and turn the screw clockwise or counter clockwise to increase or decrease the bolt lock penetration. If door has installed flush bolts in substitution to the three point lock, check its operation also. Adjustment procedure of flush bolts is the same as described for the lock bolts when a three point lock system is installed instead.
13. Apply a bead of professional grade exterior caulk around the door perimeter, over the junction of adjoining sections of door frame and opening's substrate material to create a weather tight seal and avoid air and moisture intrusion into the building. Please note that some types of sealants are not designed for exterior exposure. If caulk of an improper type is applied, an early failure of the joint should be anticipated.

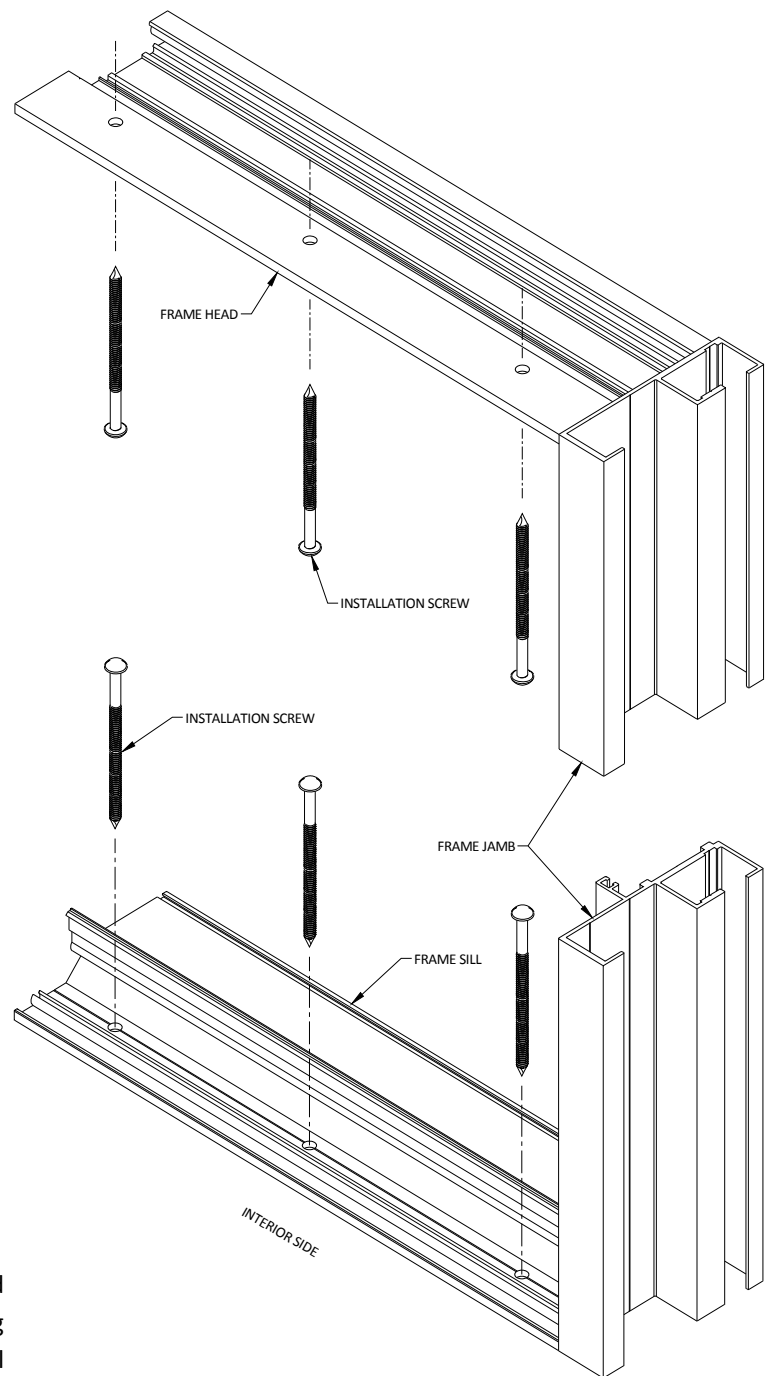

(Figure 3)

## PAIR DOOR INSTALLATION

It is recommended that the installation work should be done from the exterior side of the building.

Double doors are typically shipped with frame components and panels in separate packages. The frame requires assembly prior to its installation into the opening. Remove the frame components and panels from the shipping packaging, put the panels separate in a secure place and proceed as follows:

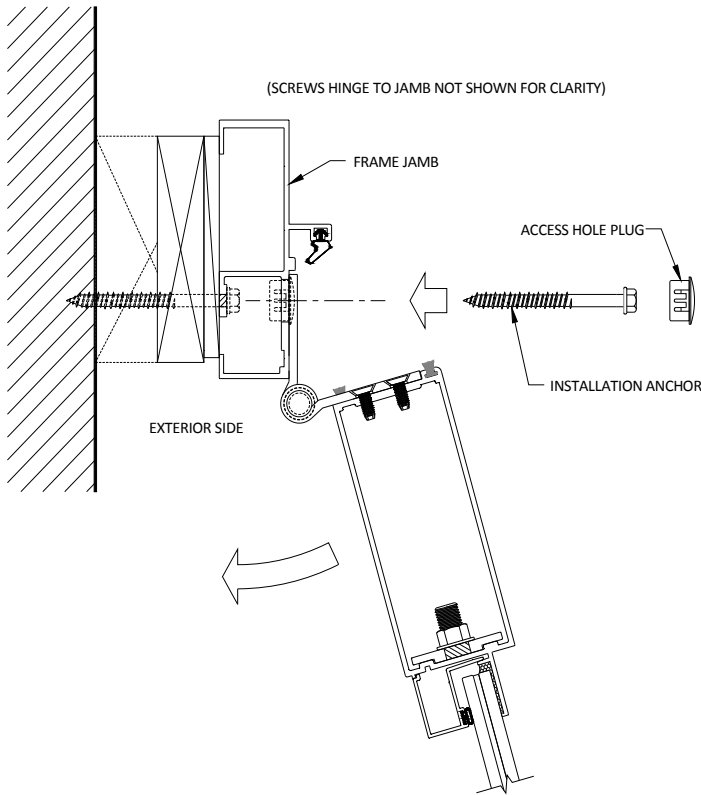

(Figure 4)

1. Start with assembly of frame components. **(Figure 6)**
  - a) Identify the frame components and place them oriented as shown in front of the opening, where door is going to be installed.
  - b) Apply a bead of silicone sealant to both ends of head and sill at the unpainted areas as indicated to seal the mechanical joints at the corners.
  - c) Attach both jambs to head and sill members using the assembly screws provided #10 x 1-1/4" PHP. PH. SMS. Insert the screws (3 per each corner) through the prefabricated holes on jambs and fasten them into the screw bosses at the head and sill members using a cordless drill with a Philips drive bit # 3.
2. Measure width and height dimensions of opening and assembled frame and make sure they are correct. The rough framed opening shall be 1/2" wider than overall frame width and 1/4" higher than overall frame height.
3. Weatherproof the sub sill. Apply a continuous 3/8" bead of exterior grade caulk, about 1/4" from the front and 1" from the rear of sub sill with a wave pattern in between. Apply a 3/8" bead of caulk to the underside of frame sill as well, where it will contact the concrete and at both frame corner joints, where the jamb meets the threshold.
4. Tilt and set the frame into the opening by seating the threshold first. Then, swing the rest of frame up into the opening. When doing this, do not scrape off the caulk poured to ensure a continuous barrier of sealant.
5. Insert shims at the top first between the frame head and the opening to hold the frame in place. Insert shims on the rest of perimeter (at both sides) between the frame jamb and the opening. Shims should be inserted at each factory predrilled hole so the installation anchors, installed later, will each fasten evenly, avoiding the bowing of frame. Wood shims or plastic slotted 'horseshoe' shims can be used.
6. Make sure the sill is level. Measure the frame diagonally and check that it is square. Measure and check that interior frame dimensions at ends and center, vertically and horizontally measured, are the same. Use a level to ensure both jambs are plumb. Make any adjustments to frame by relocating, adding or removing shims as required.

7. Once the frame is square, plumb and level in the opening, use a 1/4" diameter drill bit to perforate 2-1/2" deep into substrate at each prefabricated frame installation screw hole.
8. Drive the installation screws (not included, refer to construction plans or product's approval document for proper fastener and embedment). Start at the sill and head (**Figure 3**), then at jamba (**Figure 4**). Do not tighten the fasteners; leave them slightly loose since further adjustment might be needed.
9. Attach door panels to frame (inactive first, then the active). The hinges have been factory installed to panels. Swing out about 90 degrees the free side of each hinge attached to panel and approach panel to frame so each hole of hinge is centered with corresponding predrilled hole of jamb. Fasten the hinge screws provided #12-24 x 1/2" PHP. FH. MS. at each predrilled hole. Do not over tighten the screws since they can get damaged easily. Use a hand screwdriver or a cordless drill with Philips drive bit #3 and variable clutch settings, capable of regulating the tightening torque. (Select setting 5 - 6 on the regulating collar)

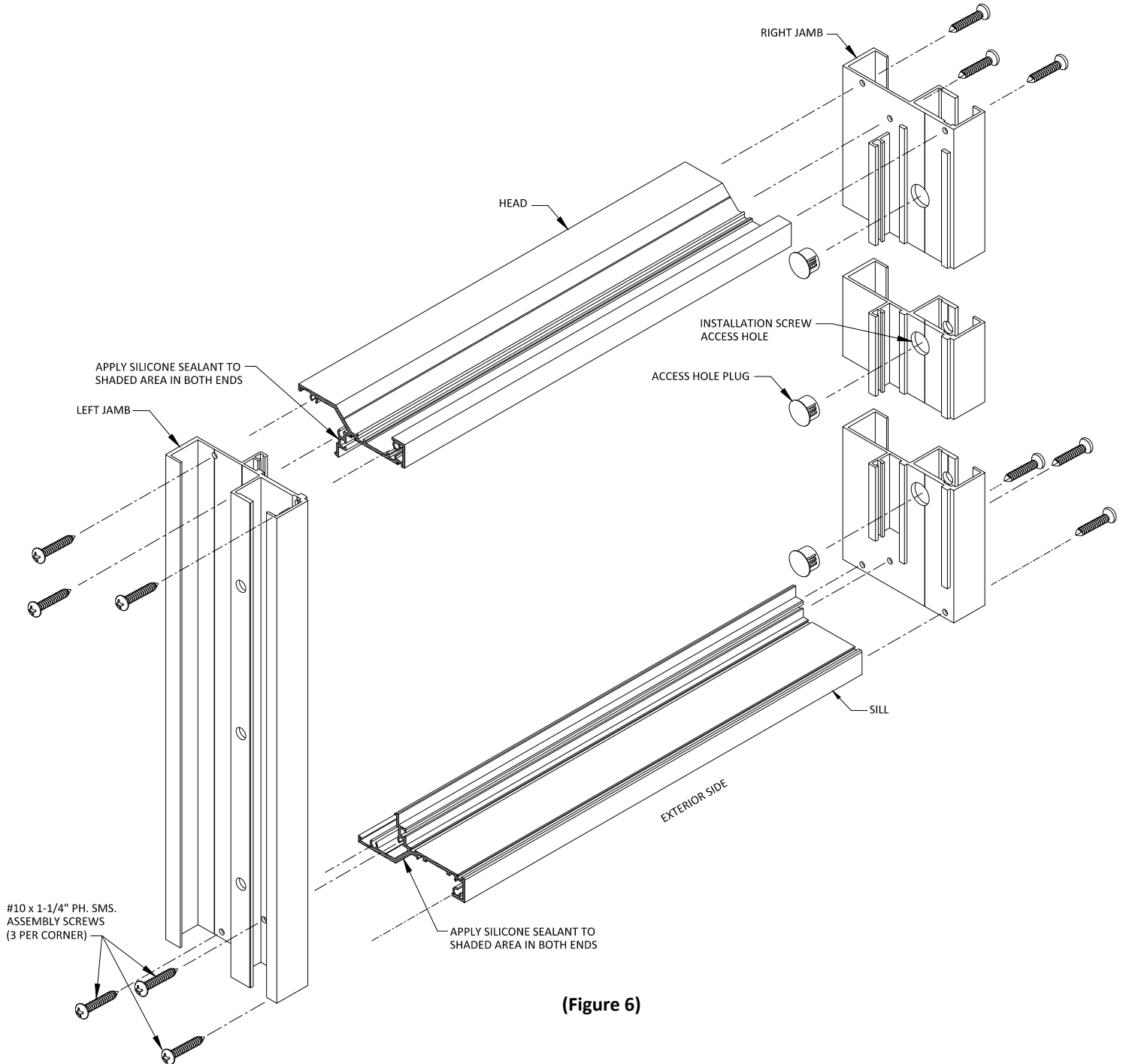

(Figure 6)

10. Swing both door panels slowly and approach them near the closed position. Check the gap between panel and frame is uniform, about 3/16", around the perimeter. If frame has been properly shimmed and installed square level and plumb, the panel should not rub the frame nor show sagging. Make any adjustments to frame until is square, level, plumb and well secured into opening.
11. Once the frame is set, from the interior, tighten the installation fasteners at head and sill (**Figure 3**). Open the panel 90 degrees to have access to jamb's installation screw access hole and tighten the rest of the fasteners (**Figure 4**). Swing the panels to the closed position and check they close properly. Then insert the plastic plugs (provided in the hardware bag) on each access hole at both jambs.
12. Install the screw covers at head and sill (provided with frame package). The cover snaps into the head and sill profiles as shown (**Figure 5**). When doing this, use a plastic head mallet and a piece of wood to hit the cover and to avoid damage to profile.
 

**Note: Do not install the screw covers until the installation of the door have been inspected and granted its approval by the Authority Having Jurisdiction or city's local Building Department. The city inspector may require physical verification to certify that installed anchors comply with corresponding product's Notice of Acceptance (NOA)**
13. Install the door lock set (strike and deadbolt) on active panel and the dummy on the inactive panel according to manufacturer's instructions included in the hardware box and check for a smooth and correct operation of the three point lock system. The length (penetration) of top and bottom bolt locks is factory adjusted. If further adjustment is needed, open the door active panel slightly to have access to the exposed adjusting screw (**Figure 1**) and turn the screw clockwise or counter clockwise to increase or decrease the bolt lock penetration. If door has installed flush bolts in substitution to the three point lock, check its operation also. Adjustment procedure of flush bolts is the same as described for the lock bolts when a three point lock system is installed instead.
14. Apply a bead of professional grade exterior caulk around the door perimeter, over the junction of adjoining sections of door frame and opening's substrate material, to create a weather tight seal to avoid air and moisture intrusion into the building. Please note that some types of sealants are not designed for exterior exposure. If caulk of an improper type is applied, an early failure of the joint should be anticipated.

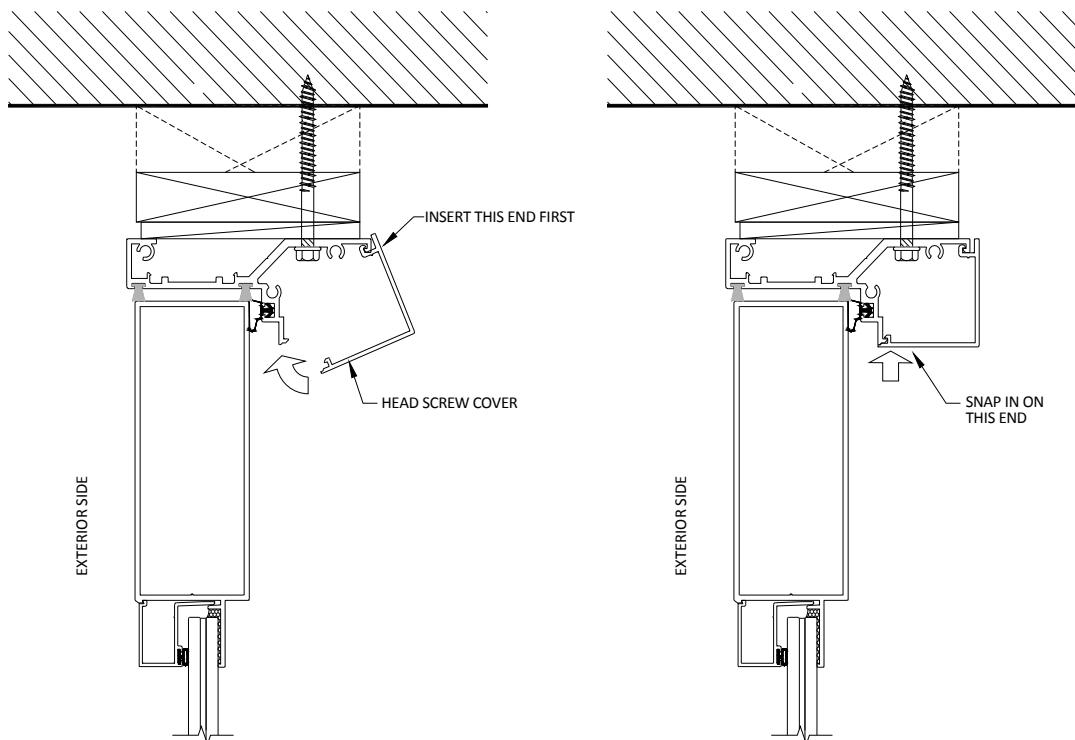

(Figure 5)

## **SIDELITE(S) ATTACHMENT TO DOOR**

It is recommended that the installation work should be done from the exterior side of the building.

A sidelite might be installed to one or both sides of the door (single or pair). Sidelites are factory assembled and packed separately of door units when shipped. The sidelite(s) must be attached to door frame prior to installation of door into opening. To attach the sidelite(s) to door frame, remove the sidelite unit from the shipping packaging, place it next to the door frame, in front of opening where door will be installed and proceed as follows:

1. Identify the sidelite jamb that will mate with door jamb to form a mullion. This will define the side location, left or right, of the sidelite unit. The sidelite's mating jamb is narrower compared with the opposite jamb that will be anchored to wall substrate (**Figure 7**). A left sidelite installation is shown in this figure, a right sidelite installation is reversed.

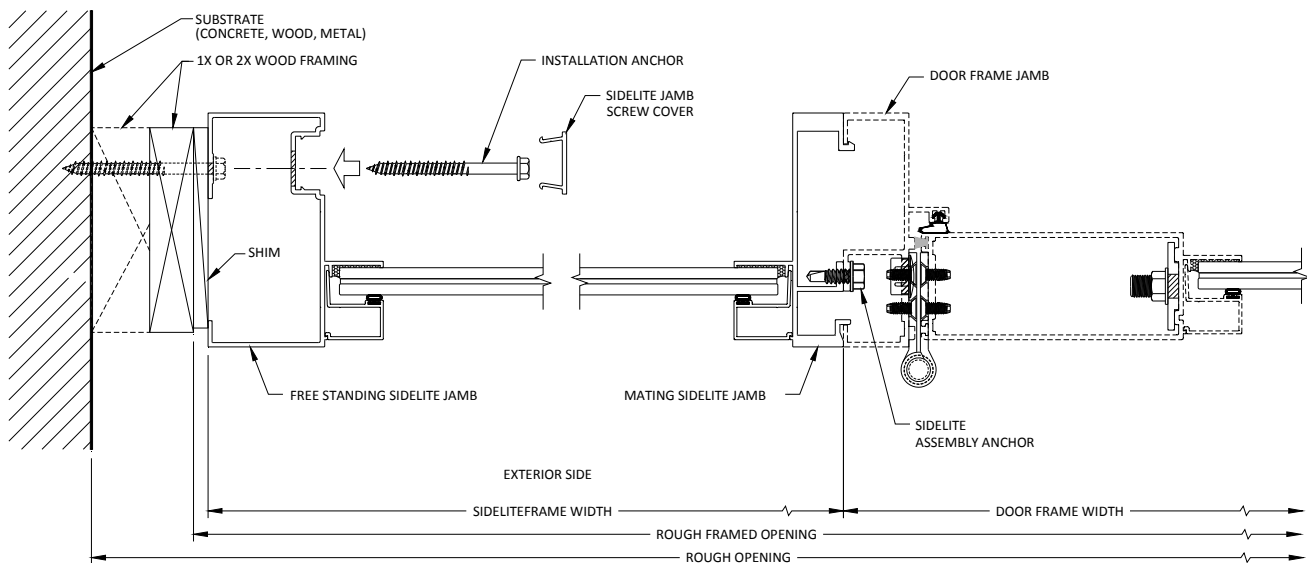

(Figure 7)

2. Once determined the side of mating jamb, verify that the sidelite has been placed on the correct side with respect to the door frame. Shift sidelite to the opposite location if it had been placed reversed.
3. Apply a 3/8" bead of silicone sealant on the exterior support leg of mating sidelite and snap the sidelite to door frame as indicated. (**Figure 8**)

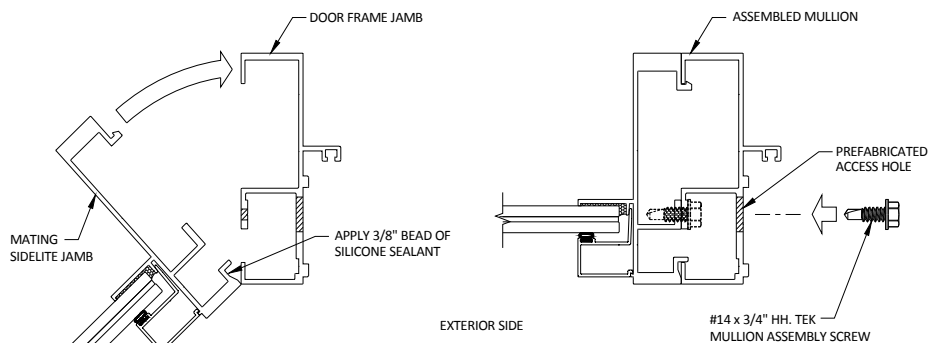

(Figure 8)

4. Insert through each prefabricated hole at door jamb the assembly screws #14 x 3/4" HH. TEK (self-drilling), provided in the hardware bag and fasten them along the mullion span using a cordless drill with a 3/8" socket (**Figure 8**)
5. Measure width and height dimensions of opening and overall frame and make sure they are correct. The rough framed opening shall be 1/2" wider than overall unit width and 1/4" higher than overall unit height.
6. Weatherproof the sub sill. Apply a continuous 3/8" bead of professional grade caulk compound, about 1/4" from the front and 1" from the rear of sub sill with a wave pattern in between. Apply a 3/8" bead of caulk to the underside of door frame sill and sidelite sill as well, where it will contact the concrete and at both frame corner joints, where the jamb meets the threshold.
7. Tilt and set the door and sidelite, as a whole unit, into the opening by seating the threshold or sill first. Then, swing the rest of frame up into the opening. When doing this, do not scrape off the caulk poured to ensure a continuous barrier of sealant.
8. Insert shims at the top first between the frame head and the opening to hold the frame in place. Insert shims on the rest of perimeter (at both sides) between the frame jamb and the opening. Shims should be inserted at each factory predrilled hole so the installation anchors, installed later, will each fasten evenly, avoiding the bowing of frame. Wood shims or plastic slotted 'horseshoe' shims can be used.
9. Make sure the frame sill is straight, flat and level. Measure the frame diagonally and check that both dimensions are the same. Also measure interior dimensions of frame at the top, mid span and bottom (vertically and horizontally) and check they are the same. Use a level to ensure both frame jambs are straight and plumb. Make any adjustments to frame if needed by relocating, adding or removing shims as required.
10. Once the frame is square, plumb and level in the opening, use a 1/4" diameter drill bit to perforate 2-1/2" deep into substrate at each pre-fabricated installation hole of door and sidelite(s) frames.
11. Drive the installation screws (not included, refer to construction plans or product's approval document for proper fastener and embedment). Start at the sill and head (**Figure 3**), then at jambs (**Figures 4 and 7**). Do not tighten the fasteners; leave them slightly loose since further adjustment might be needed.
12. Attach the door panel to frame as described above in SINGLE DOOR INSTALLATION or PAIR DOOR INSTALLATION sections and follow the rest of the steps of such applicable sections regarding panel adjustment, hardware installation and caulking of the exterior perimeter.

**END OF INSTRUCTIONS**